



Datasheet

Multi-gap Gas Discharge Tube (MGDT)

Series / Models	5G-8E Series
Product Code	10.15.80.XXXX
Version	A6
Date	2026-05-07
File Number	SP-GDT-143

Version History

Version	Date	Page	Description	Author
A0	2023-11-06	/	Initial draft	George Hu
A1	2024-01-12	Page 7	Update Packaging Specifications	George Hu
A2	2024-01-30	Page 6	Update Packaging Information	George Hu
A3	2024-05-14	Page 4	Update Electrical Characteristics	Xia Wu
A4	2024-09-10	Page 4,5	Add Model 5G800-8E-C	Xia Wu
A5	2025-06-13	Page1,2,3	1. Add cover and version history 2. Update description	Xia Wu
A6	2026-05-07	Page 4	Update Electrical Characteristics, add UL Certifications and change marking, add 1200 specification and remove2000 specification.	Xia Wu

Multi-gap Gas Discharge Tube (MGDT)

5G-8E Series

Description

Gas discharge tubes (GDTs) are generally in a high insulation resistance state, equivalent to an open circuit, which has almost no impact on the normal operation of the circuit. When transient overvoltage occurs in the circuit and the voltage amplitude exceeds the breakdown voltage of the GDT, the gas inside the GDT is ionized, causing the GDT to quickly conduct and limit the overvoltage to a lower level, thereby protecting electronic devices or circuit components connected in parallel from high voltage impact damage. After the overvoltage disappears, the GDT immediately returns to a high insulation resistance state, and the circuit resumes normal operation.



The 5G-8E series is a multi-gap GDT with a surface mount package and 5 discharge gaps inside. So this product has a higher arc voltage and can be directly used for 48V~60V DC power supply. The application of suitable auxiliary circuits can achieve excellent protection levels.

Features

- I Stable performance over life
- I Very fast response time
- I High insulation resistance
- I SMD Component
- I Non-Radioactive

Applications

- I DC power supply protection
- I Wireless base station

Part Number Code

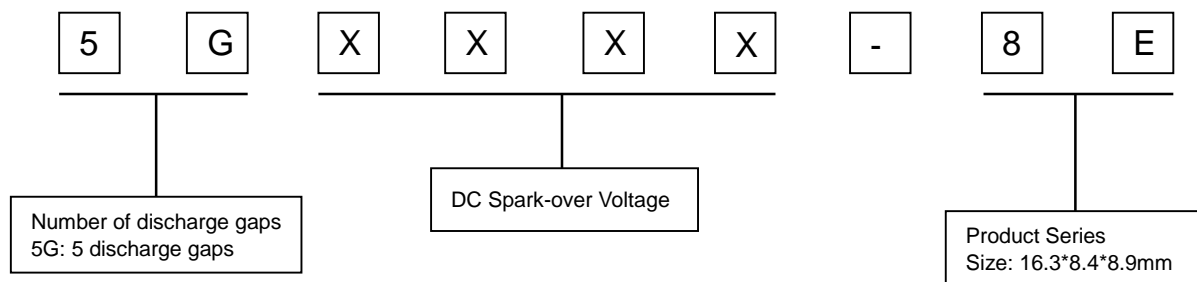

Multi-gap Gas Discharge Tube (MGDT)

5G-8E Series

Electrical Characteristics

Model	5G800-8E 5G800-8E-C	5G1200-8E 5G1200-8E-C	5G1400-8E 5G1400-8E-C	Units
DC spark-over voltage ¹⁾²⁾³⁾ at 100V/S				
Initial arrester only	800±25%	1200±25%	1400±25%	V
with capacitors ⁴⁾	<750	<1200	<1250	V
After service life arrester only	500~1200	700~1600	900~2000	V
Impulse spark-over voltage ³⁾ at 1KV/μs				
Initial arrester only	<1300	<1800	<2100	V
with capacitors ⁴⁾	<800	<800	<800	V
After service life arrester only	<1800	<2100	<2300	V
with capacitors ⁴⁾	<1400	<1500	<1600	V
Front of wave spark-over voltage ³⁾ at 1.2/50 μs, 6 kV				
Initial arrester only	<1500	<2000	<2300	V
with capacitors ⁴⁾	<900	<900	<900	V
After service life arrester only	<2000	<3000	<3000	V
with capacitors ⁴⁾	<1500	<1600	<1600	V
DC operating voltage ⁵⁾	48±20%	48±20%	60±20%	V _{DC}
Service life ³⁾				
Normal impulse discharge current 8/20μS ±5 times	20	20	20	KA
Impulse discharge current 10/350μS ±5 times	4	4	4	KA
Impulse life 10/350μS ±50 times	500	500	500	A
Impulse life 10/1000μS ±150 times (alternating polarity)	100	100	100	A
Insulation resistance at DC 100V	>1	>1	>1	GΩ
Arc voltage at 30A	≥60	≥60	≥72	V
Capacitance at 1MHz	<1	<1	<1	pF
Weight	~5.1	~5.1	~5.1	g
Operation and storage temperature	-40~+125	-40~+125	-40~+125	°C
Climatic category (IEC60068-1)	40/125/21	40/125/21	40/125/21	
Certifications  UL1449 E508408	◎	◎	◎	
Marking, red positive	Without	Without	Without	
Surface treatment	Matte-tin plated			
Moisture sensitivity level ⁶⁾	1			

¹⁾ At delivery AQL 0.65 level II, DIN ISO 2859.

²⁾ In ionized mode.

³⁾ Test the electrodes at both ends (between a and b).

⁴⁾ Refer to circuit diagram on page 7.

⁵⁾ DC current source 30 A.

⁶⁾ Tests according to JEDEC J-STD-020.
Terms in accordance with IEC 61643-11.

Multi-gap Gas Discharge Tube (MGDT)

5G-8E Series

Dimensions

5GXXX-8E

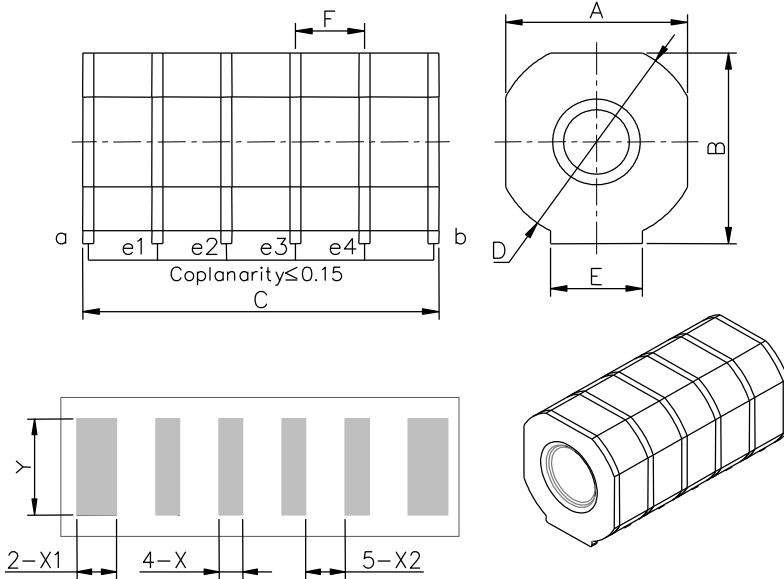

Recommended Soldering Pad Layout

Symbol	Millimeters	Inches
A	8.4±0.3	0.331±0.012
B	8.9±0.3	0.350±0.012
C	16.3±0.5	0.642±0.020
D	φ9.3±0.3	0.366±0.012
E	4.2±0.2	0.165±0.008
F	~3.2	~0.126
X	1.2	0.047
X1	2	0.079
X2	2	0.079
Y	4.5	0.177

5GXXX-8E-C

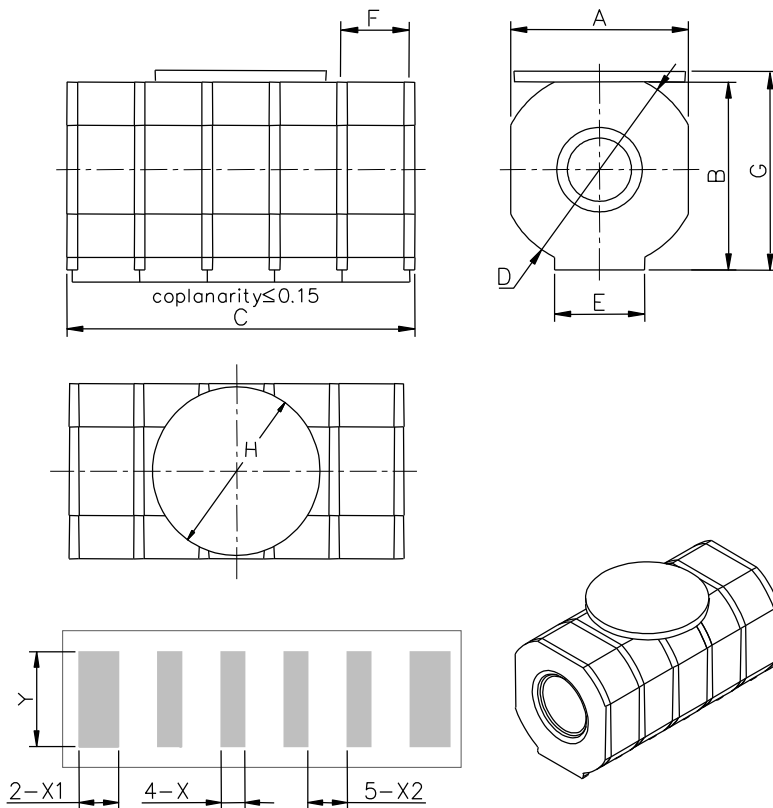

Recommended Soldering Pad Layout

Symbol	Millimeters	Inches
A	8.4±0.3	0.331±0.012
B	8.9±0.3	0.350±0.012
C	16.3±0.5	0.642±0.020
D	φ9.3±0.3	0.366±0.012
E	4.2±0.2	0.165±0.008
F	~3.2	~0.126
G	9.5±0.3	0.374±0.012
H	Φ8.0	0.315
X	1.2	0.047
X1	2	0.079
X2	2	0.079
Y	4.5	0.177

Multi-gap Gas Discharge Tube (MGDT)

5G-8E Series

Packaging Information

Tape Specifications

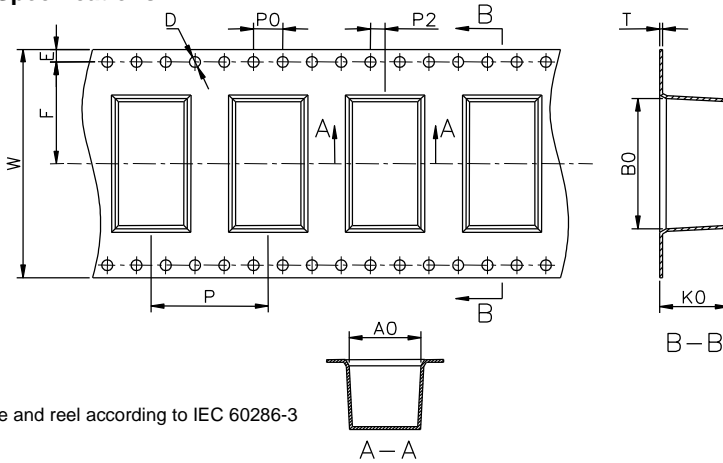

Tape and reel according to IEC 60286-3

Reel Specifications

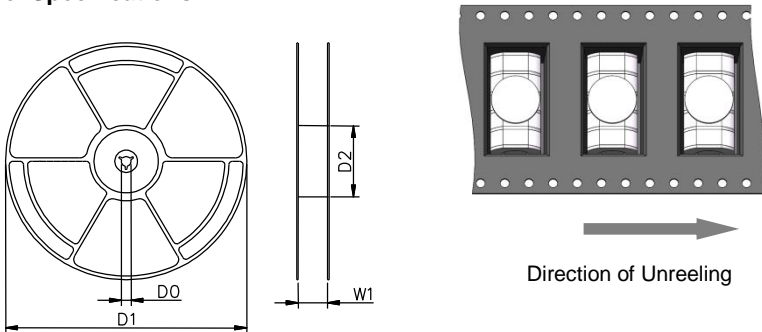

Symbol	Millimeters	Inches
W	32±0.3	1.260±0.012
A0	8.8±0.1	0.346±0.004
B0	17.1±0.1	0.673±0.004
K0	10.3±0.2	0.406±0.0079
P	16.0±0.1	0.630±0.004
E	1.75±0.1	0.069±0.004
F	14.2±0.1	0.559±0.004
D	1.5+0.1/-0.0	0.059+0.004/-0.0
P0	4±0.1	0.157±0.004
P2	2±0.1	0.079±0.004
T	0.4±0.1	0.0157±0.004
D0	13.3±0.15	0.524±0.006
D1	330±2	12.992±0.079
D2	100+1/-2	3.937+0.039/-0.079
W1	33+1/-0.5	1.299+0.039/-0.0197

	Reel	Inner Box	Carton
Size	330×35mm	340×333×70mm	375×353×380mm
Quantity	MPQ/MOQ: 1 reel=300pcs	1 Inner Box=2 reels=600pcs	1 Carton=5 Inner boxes=3,000pcs
Photos			

Multi-gap Gas Discharge Tube (MGDT)

5G-8E Series

Soldering Parameters - Reflow Soldering (Surface Mount Devices)

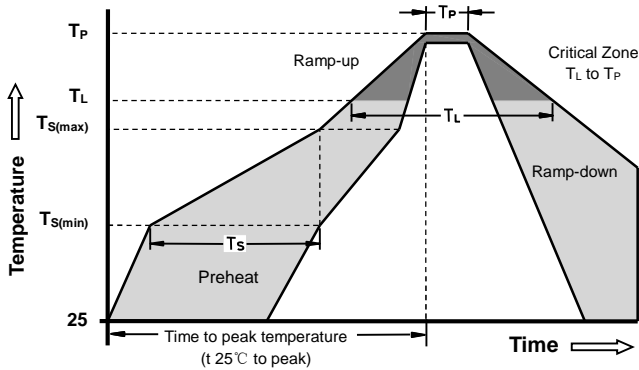

Reflow Condition		Pb - Free assembly
Preheat	- Temperature Min ($T_{s(min)}$)	150°C
	- Temperature Max ($T_{s(max)}$)	200°C
	- Time (min to max) (t_s)	60 - 180 Seconds
Average ramp up rate (Liquids Temp T_L) to peak		3°C/second max
$T_{s(max)}$ to T_L - Ramp-up Rate		5°C/second max
Reflow	- Temperature (T_L) (Liquids)	217°C
	- Time (min to max) (t_s)	60 - 150 Seconds
Peak Temperature (T_P)		260 +0/-5°C
Time within 5°C of actual peak Temperature (t_p)		10 - 30 Seconds
Ramp-down Rate		6°C/second max
Time 25°C to peak Temperature (T_P)		8 minutes Max
Do not exceed		260°C

Application Circuit (C1 to C4 = each capacitor 100 pF to 470 pF, withstand voltage 2KV)

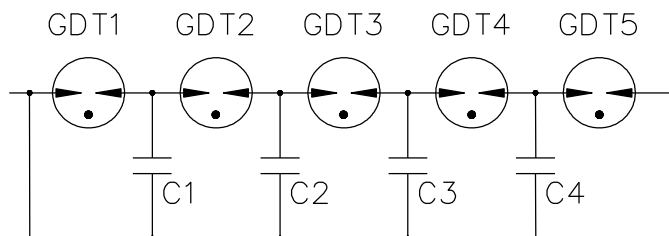

Terms and definitions

NO.	Item	Definitions
1	Gas discharge tube(GDT)	A gap, or several gaps, in an enclosed discharge medium, other than air at atmospheric pressure, designed to protect apparatus or personnel, or both, from high transient voltages. Also referred to as "gas tube surge arrester".
2	DC Spark-over Voltage	The voltage at which the gas discharge tube sparks over with slowly increasing d.c. voltage.
3	Impulse Spark-over Voltage	The highest voltage which appears across the terminals of a gas discharge tube in the period between the application of an impulse of given wave-shape and the time when current begins to flow.
5	Arc voltage	Voltage drop across the GDT during arc current flow.
6	Glow voltage	Peak value of voltage drop across the GDT when a glow current is flowing.
7	Impulse discharge current 8/20μs	Current impulse with a nominal virtual front time of 8 μ s and a nominal time to half-value of 20 μ s.
8	Alternating Discharge Current	The rms value of an approximately sinusoidal alternating current passing through the gas discharge tube.
9	Insulation Resistance	Insulation resistance shall be measured from each terminal to every other terminal of the GDT. The test is performed with DC50V when normal spark-over Voltage 70~150V, others with DC100V.
10	Capacitance	The capacitance shall be measured once at 1 MHz between all terminals unless otherwise specified.

Cautions

- I Do not operate gas discharge tubes in power supply networks, whose maximum operating voltage exceeds the minimum spark-over voltage of the gas discharge tubes.
- I Gas discharge tubes may become hot in the event of longer periods of current stress (burn risk). In the event of overload the connectors may fail or the component may be destroyed.
- I Gas discharge tubes must be handled with care and must not be dropped.
- I Do not continue to use damaged gas discharge tubes.
- I The shown SMD pad dimensions represent a safe way to mount the arrester and are a recommendation of the manufacturer. During the reflow process it must be assured that no solder material reduces the insulation distance between the pads below the arrester.
- I SMD gas discharge tubes should be soldered within 24 month after shipment.
- I The electrical characteristics described in this datasheet are only typical characteristics, and all of these characteristics have been confirmed through testing and inspection. If the customer's usage requirements are different from this or have special requirements, please contact Ruilongyuan Electronics Co., Ltd. If protection failure or circuit damage occurs as a result, our company is not responsible for it.
- I Ruilongyuan Electronics Co., Ltd. always strives to improve our products. Consequently, the products described in this datasheet may be updated from time to time, and the corresponding product specifications may also be updated accordingly. So, before or at the time of placing your order, please check to what extent the product descriptions and specifications contained in this publication are still applicable. Ruilongyuan Electronics Co., Ltd. still reserves the right to cease production and delivery of products. Consequently, we cannot guarantee that all products listed in this datasheet will always be available. The above provisions do not apply to individual agreements with customers for specific products.
- I Ruilongyuan Electronics Co., Ltd. models may have different product codes. Different product code representations are due to the use of different production processes, but do not affect their respective product specifications.